

1200L PACKAGED PUMP STATION

SEWAGE

IDEAL FOR DOMESTIC SEWAGE AND DRAINAGE APPLICATIONS

PACKAGE INCLUDES

- Heavy Duty Roto-molded 1200 L polyethylene tank
- REEFE REG015 grinder pump with automatic control
- Complete with 40mm discharge piping, valves and fittings including brass gate and swing check valve, and barrel union for easy connection and pump removal
- High level alarm with audible and visible alarm functions
- Australian made and assembled ready for installation



REEFE Liquid Level Alarm (RLA10)



REEFE Submersible Pump (REG015)



Cast Iron Impeller Components



Stainless Steel Grinder Components

FEATURES

- 1200L Nominal Capacity
- Approved to requirements of Australian Standard AS/NZS1546.1
- Tough UV stabilised rotationally moulded polyethylene vessel
- Proven UV stabilised injection moulded lid (RELN Septic Tank)
- Easy 100mm PVC Sewer Pipe inlet connection via Pipe Gasket Seal
- Variable inlet height to suit fall or volume required (between 1000L and 900L). Simply drill to desired height in marked positions
- Flanged base designed for hold-down by backfill
- Unique tie down locations on underside of base suit attachment with reo bar set and additional unique flange penetrations for concrete lock down in higher water table areas
- Specially shaped base designed for
 - maximum strength
 - maximum pump out
- Class B and Class D Ductile Iron Access Covers available
- Dual Pump Systems available

1200L PACKAGED PUMP STATION REEFE REG015 DETAILS

SEWAGE

ELECTRICAL DATA

- Rated Voltage: 240V
- Mains Frequency: 50Hz
- Rated output: 1.5kW
- Current: 9.5A
- Capacitor: 30 μ F
- Motor Duty: Continuous
- Motor Type: Asynchronous
- Motor protection: Built-in thermal overload
- Ingress protection: IPX8
- Insulation class: B
- Power cable length: 10m H07RNF

LIQUIDS

- Clean water temperature range: 40 °C

MATERIALS

- Pump body: Cast Iron
- Motor shroud: 304 Stainless Steel
- Impeller: Cast Iron
- Motor Shaft: Stainless Steel
- Cutting Device: Stainless Steel
- Shaft seal: Dual mechanical seals (Ceramic/Carbon)

INSTALLATION

- Max. Ambient temperature: 40°C
- Pipe Connection: 2"

SPECIFICATIONS

Overall height: 1698mm
Overall diameter: 1250mm
Weight: 113kg
Nominal Capacity: 1200L

HYDRAULIC PERFORMANCE CHART

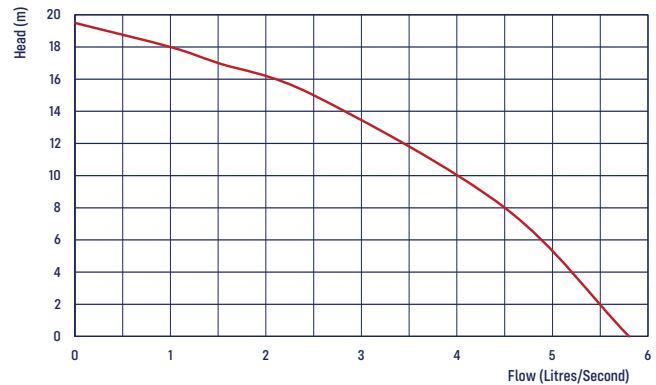

SITE EXCAVATION DIMENSIONS

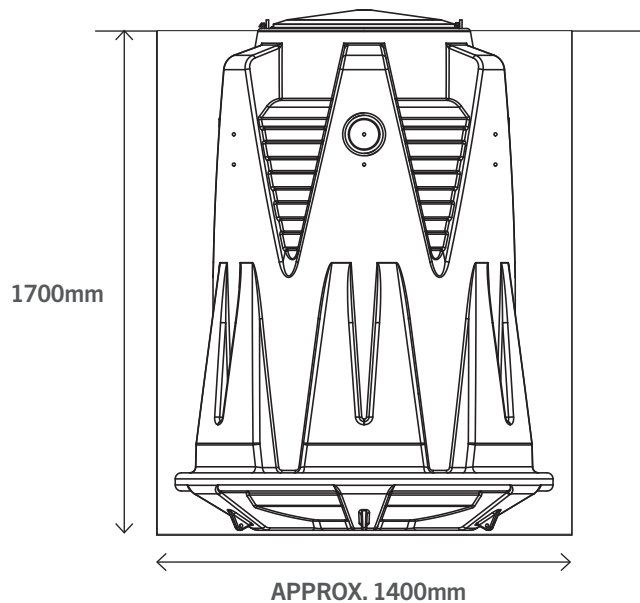

CONTACT US

Alphatreat Pty Ltd
ABN 64 143 207 658

9 Mackie Way, Brendale, QLD, 4500
Phone: 07 3205 3666
Facsimile: 07 3205 7155
Hours: 7:30am - 4:00pm (Mon-Fri)
Email: info@wastewaterequipment.com.au

wastewaterequipment.com.au